

EcoController GEL 8180

Camshaft gear

MOTIONLINE

LENORD+BAUER

Technical Information

Version 01.03



Design, Construction

Design

The camshaft gear is based on our EcoController and is designed for installation in a switch cabinet. It can be operated individually or cross-linked. At the core of the EcoController hardware is a fast 16-bit microprocessor and a powerful peripheral ASIC developed especially for the demands of motion automation. The housing is made of sheet metal (Zincor).

The electronic camshaft gear has significant advantages over mechanical solutions:

- short change-over times
- easy adjustment
- no operating cycle
- no contact bouncing
- no mechanical wear
- no maintenance

Range of application

The electronic camshaft gear can be used wherever mechanical solutions are to be replaced.

Examples for applications are:

- paper making machines, packaging machines and coiling machines
- steel works and rolling mill technique
- presses and automatic punching machines
- materials handling and storing technique
- mechanical treatment machinery

Example for application:

Control of a bag filling machine

In order for a machine to fill bags with granulate, 7 different operations are necessary. They are repeated in a cycle (see diagram). The position is recorded by an absolute encoder (resolution 1°). The cams have power outputs. Up to 99 different programmes are available for various bag sizes and types of granulate.

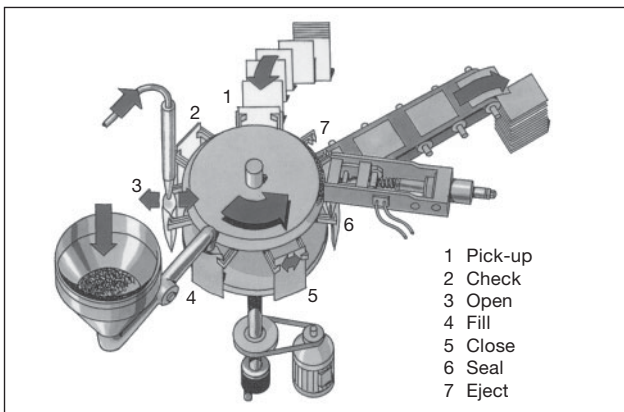

Characteristics

- Up to 64 tracks
- Up to 3584 variably adjustable cams
- Up to 99 programmes
- Input frequency-dependent displacement of cams (dynamic cam)
- Short cycle time, 300 µs without dynamic cams
- Temporary lock of individual tracks or track groups

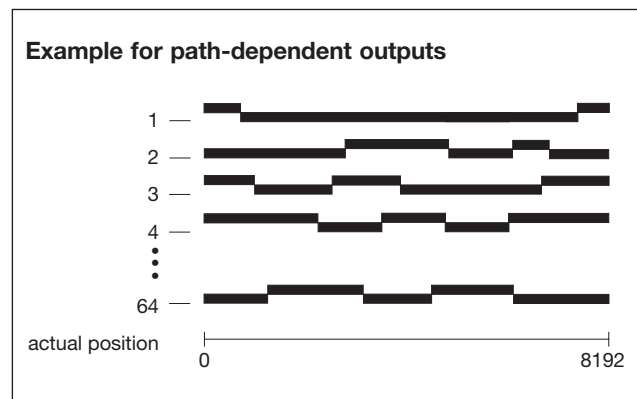

Digital inputs/outputs

In the basic version, the Controller has

- digital outputs
- digital inputs (connectors E2, E3 are not assigned)

All digital outputs operate with 24 V levels common in industry. All digital outputs are short-circuit proof and protected against polarity reversal. The output status of 24 outputs can be displayed via 24 (programmable) LEDs.

Actual value acquisition

There are various encoder inputs available to record the actual values of rotation, distance, or angle:

- one counting input for 5 V or 24 V incremental encoders
- one SSI input for absolute encoders in Gray code (13 bit/25 bit)

Communications interfaces

The controllers can easily be cross-linked with the aid of two shunt-connected, 9-pin D-subminiature connectors. Available are:

- two RS 485 and one RS 422/485 communications interfaces independent of one another (connector B1, B2)
- one RS 232 interface (connector C)
- PROFIBUS DP (connector P)
- InterBus-S (connector I)



Field bus Programming, Operation

Field bus

The input and output of process data (nominal/actual values) and all control signals, as well as parametering can also be carried out via the PROFIBUS or InterBus-S, which considerably reduces materials and wiring costs in comparison to conventional parallel communication.

The PROFIBUS module is an intelligent interface RS 485 (1 line pair) that can transfer data in accordance with DIN E 19245 part 3 (PROFIBUS DP). The maximum transfer rate is 1.5 Mbaud. An InterBus-S module according to DIN E 19258 (2 line pairs) with the same functions may be used alternatively. Connectors A2 and A3 are replaced by two 9-pin P connectors or I connectors.

Programming

The distribution of the 3584 cams between the programmes and the paths can be determined by the individual user. Inputting the cams is carried out via the operator terminal. Still more convenient is using the BB 8180 „Operating + Observing“ PC programme to edit, store and load the cams into the controllers or to read them out from the controllers. Of course the controllers can also be configured via this programme.

The „Operating + Observing“ PC programme also allows you to carry out communication with an individually operated controller or with a complex controller network. An automatic backup function reads the data and configurations of all the controllers that are cross-linked and independently generates the files necessary for system management. The option of saving data onto storage media allows for a better overview of the diverse controller files. At the same time, the files can also be printed out.

System requirements for the BB 8180 PC programme

- 80386 PC or higher (MS-DOS 3.30 or higher)
- 3.5" floppy disk drive and hard disk drive
- RS 232 interface

If you are cross-linking several controllers, your PC requires an RS 485 interface. If your PC does not have such an interface, then we can offer you the following solutions:

- GEL 89010 V 24 / RS 485 converter incl. power supply unit
- GEL 89011 V 24 / RS 485 converter with electrical signal isolation incl. power supply unit, GEL 8810 operator terminal

GEL 8810 operator terminal

The GEL 8810 operator terminal with front dimensions of 160 mm x 160 mm is designed for operation and observation in close proximity to the controller. The 18 mm x 18 mm quick stroke keys can be labelled with user-specific insertion strips.

The high-illumination, high-contrast display has an alphanumeric LCD dot matrix display (4 x 20 characters, 8 mm high) with LED background lighting. The self-explanatory display text (bilingual) uses menus to guide the user through the programming of functions and operating values. In addition, there are also convenient editing features such as:

- inserting cams or paths
- copying cams or paths, even outside of programmes
- deleting cams, paths, programs, units and the entire memory
- scrolling through memory contents, etc.

With the EcoControllers, machine parameters and nominal value programmes can be edited or actual and nominal values can be visualized.

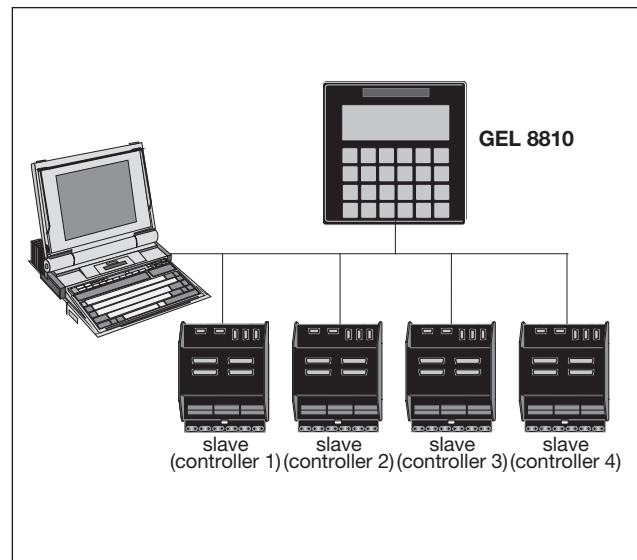

Further information about the GEL 8810 operator terminal is available on a separate technical information.

Technical data

Supply voltage	
input	18 ... 30 V DC (U_B) or 15 ... 23 V AC
current consumption	approx. 300 mA
output	$U_B - 1$ V
load current	approx. 400 mA
Counting inputs	
logic level	24 V low: 0 ... +5 V high: +15 ... +30 V
	5 V low: 0 ... +0.8 V high: +2.5 ... +5 V
input resistance	24 V > 2.5 k Ω
	5 V > 3 k Ω
input frequency	\leq 200 kHz
pulse width of zero signal	2.5 μ s
encoder supply	24 V approx. $U_B - 1.5$ V (max. 26 V)
	5 V 5 V \pm 5% stabilized with sense line
SSI inputs	
data, cycle	as per specification RS 422
cycle frequency	approx. 375 kHz
encoder supply	$U_B - 1.5$ V (max. 26 V)
Logic input (terminal strip)	
level	low: 0 ... +5 V high: +15 ... +30 V
input resistance	> 10 k Ω
Logic output (terminal strip)	
I_{max}	300 mA, 8 outputs together max. 600 mA, sustained short circuit-proof
reaction time at overload	\geq 1 μ s
voltage supply	external 8 ... 30 V DC
Digital output (cam 17 ... 64)	
outputs	2 x 24
I_{max}	20 mA per output: 200 mA totally for all 48 outputs
voltage supply	$U_B - 1$ V

Serial interfaces	3
Ser1	RS 485 or RS 232 C, galvanically separated via optocoupler
Ser2	RS 422
Ser3	RS 485 galvanically separated via optocoupler
Actual value range	0 ... 8,191 (max. 64 tracks) 0 ... 16,383 (max. 32 tracks)
Number of axes	1
Number of cams	3,584
Scan time	300 μ sec + 150 μ sec per created group of dynamic cams + 50 μ sec for an SSI encoder
Climatic applicability class	KWF (acc. to DIN 40040)
relative humidity of air	up to 95 %, no condensing
operating temperature range	0 $^{\circ}$ C ... 50 $^{\circ}$ C
storage temperature range	-20 $^{\circ}$ C ... +80 $^{\circ}$ C
EMC (observance of assembly instructions is mandatory)	
electromagnetic emissions	acc. to EN 50081-1
electromagnetic immunity	acc. to EN 50082-2
The GEL 8180 is in strict conformity with Directive EMC 89/336/EEC of the European Union and is therefore certified by the CE mark.	
Display	
standard	2 LEDs
option	24 LEDs signaling the switch position of inputs and outputs
Housing	
material	sheet metal (Zincor) powder-lacquered black
fixture	snap-on mounting on top hat rail as per DIN EN 50022-35 or simple fastening with screws
weight	approx. 1.2 kg
Protection class	IP 20

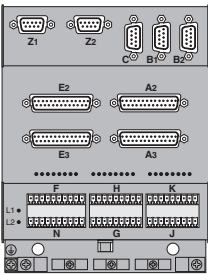

Connectors Z1, Z2

(counting inputs for an incremental encoder)

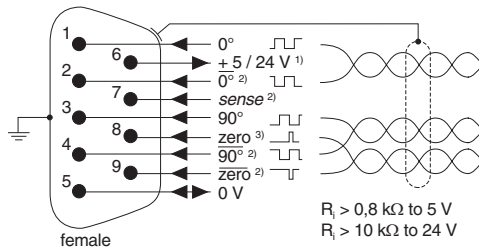

- ¹⁾ change with DIP switch (same voltage value as at N4, 26 V max.)
- ²⁾ do not connect if not used
- ³⁾ alternative: sensor signal for *reference fine* function; if you use different voltage levels for the encoder (5 V) and the sensor (24 V) adjust with DIP switch accordingly

E281047Z

Connectors B1, B2

(serial interfaces)

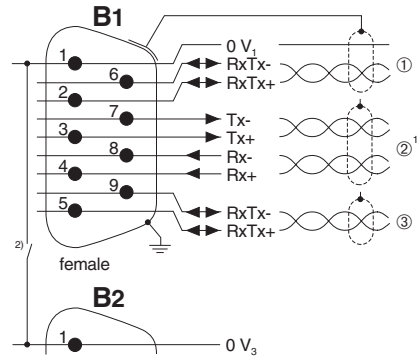

- ① Ser1: RS 485 with galvanical separation (PC etc.)
- ② Ser2: RS 422/485 (daisy chaining EcoController)
- ③ Ser3: RS 485 with galvanical separation (operator terminal GEL 8810)

- ¹⁾ switch on von RS 422 auf RS 485 mittels DIP switch
- ²⁾ close DIP switch if several EcoControllers form a cascade arrangement

E281047B

Connectors Z1, Z2

(actual value input for an absolute encoder)

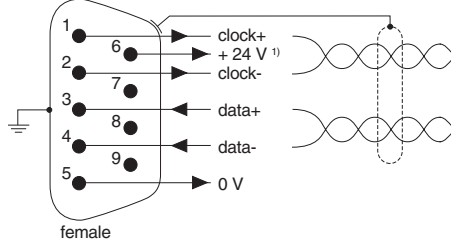

- ¹⁾ change with DIP switch (same voltage value as at N4, 26 V max.)

E281047S

Connectors A2, A3

(data outputs)

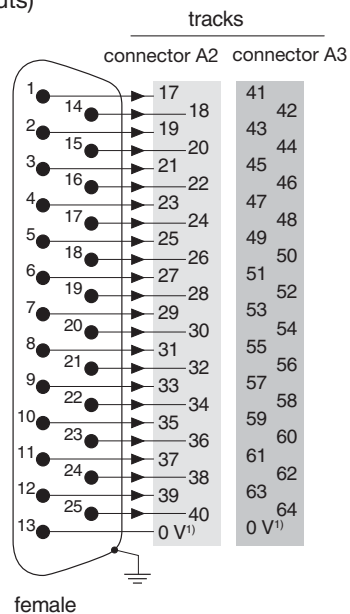

- ¹⁾ alternative: +8 ... 30 V in case of external signal supply (programmable)

E281847A

Connector C

(serial interfaces RS 232 C)

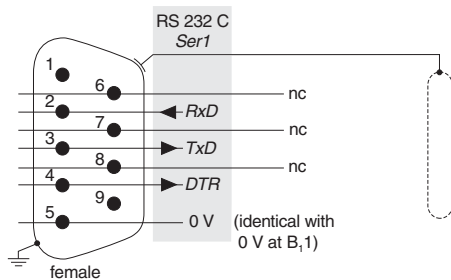

E281047C

Pin layouts

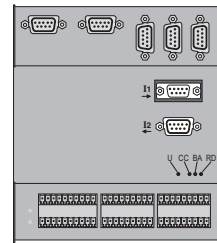

Connectors P (two PROFIBUS ports connected in parallel)

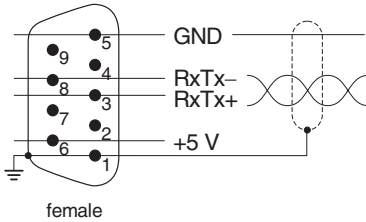

Important!
The bus terminator GEL 89030 which is included in the scope of supply must absolutely be plugged into connector P.

E281047P

Connectors I (InterBus-S)

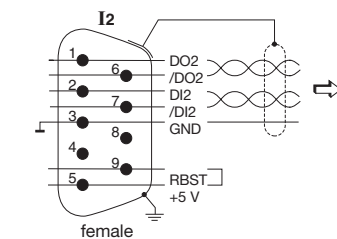
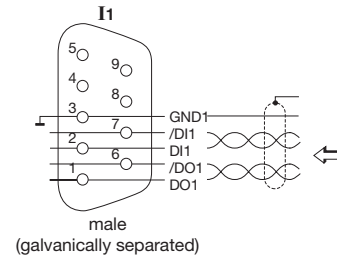

E281047I

Terminal strip N (supply voltage)

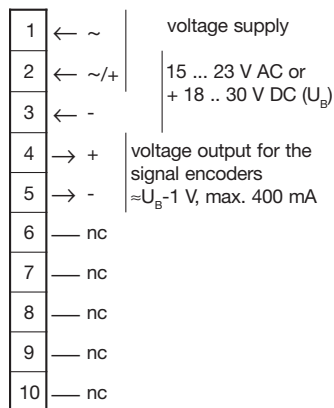

E281825N

Terminal strip F (cam output)

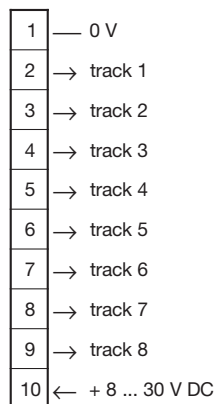

E281825F

Terminal strip G (control inputs)

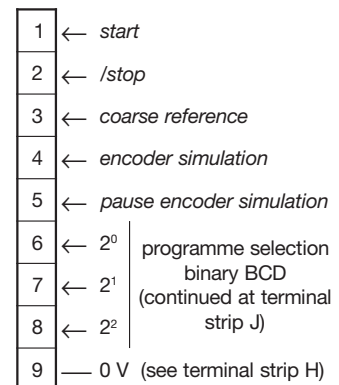

E281825G

Terminal strip H (cam output)

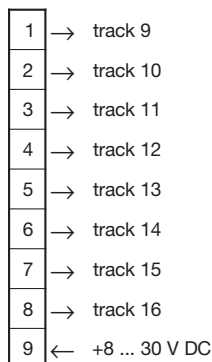

G

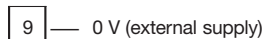

E281825H

Terminal strip J (control inputs)

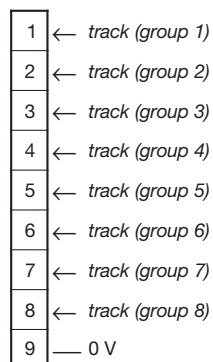

E281825J

Terminal strip K (control outputs)

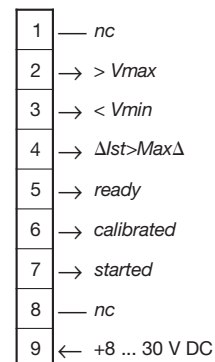

J

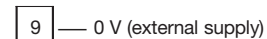

E281825K

Dimensioned drawings

EcoController GEL 8180
for mounting on top hat rails

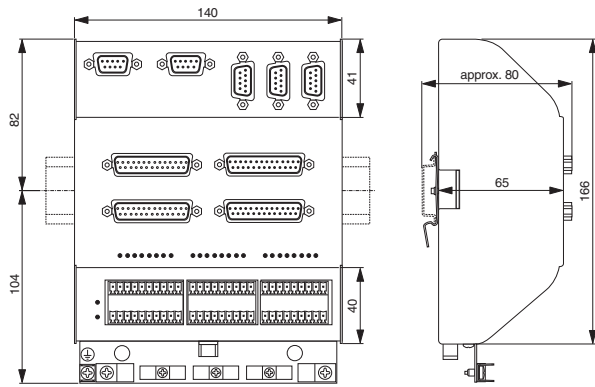

E281136E

EcoController GEL 8180
for back panel mounting

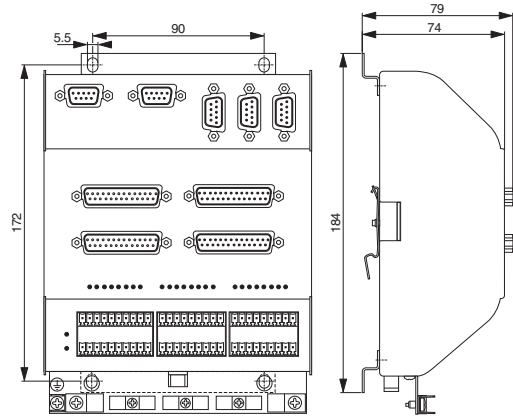

E281136D

Mains transformer GEL 7923

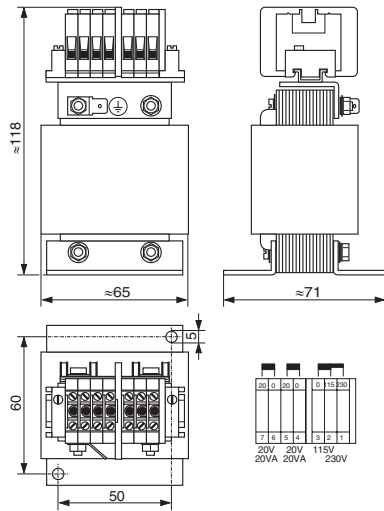

X6203H

Mounting plate GEL 7922

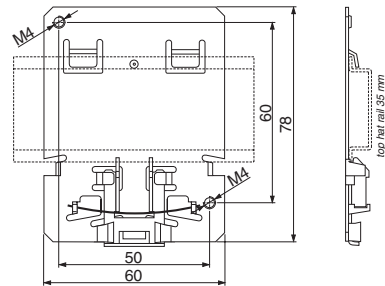

E6101CH

Line filter GEL 7925

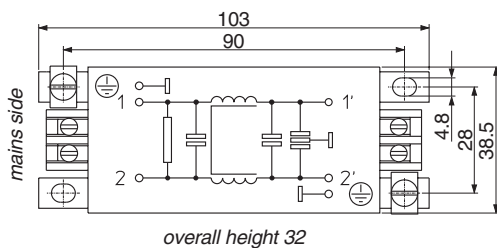

E6101AH

Type code

				actual value inputs			
				0	not mounted		
				A	incremental counter input 24 V		
				B	incremental counter input 5 V		
				S	absolute SSI encoder		
					data input / output		
				0	not mounted		
				6	48 data outputs, 48 data inputs, 24 LEDs		
				8	InterBus-S		
				9	PROFIBUS DP		
8180	A	0	-	0	-	0	0

PC software

Operating and Observing

BB 8180

cable from operator terminal GEL 8810 to EcoController

GEL 89019

Accessories

converter (V24/RS485) incl. supply unit

GEL 89010

connection cable RS 232C between PC and EcoController

GEL 89022

converter (V24/RS485)

D-type subminiature adapter:

with galvanic signal separation

● 25-pole male to 9-pole female

GEL 89025

incl. supply unit

● 25-pole male to 25-pole female

GEL 89026

cable from converter to EcoController

GEL 89011

● 9-pole male to 9-pole female

GEL 89027

cable from EcoController to EcoController

GEL 89015

bus terminal connector (PROFIBUS DP)

GEL 89030

● transmitter/receiver

GEL 89016 SED

mounting plate for mains transformer

GEL 7922

● receiver/receiver

GEL 89016 EED

mains transformer

GEL 7923

line filter with current-compensated chokes
250 V~

GEL 7925